

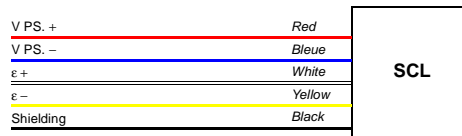

Description

The measurement principle used in the SCL load cell is based on the deformation of beams to which a compression force is applied. It uses strain gauges arranged to form a Wheatstone bridge for conversion of the force to an electrical signal. The SCL load cell is specially designed to be insensitive to excentric loads while remaining compact.

Wiring



Applications

- Weighbridges.
- Weighing of tanks, silos, etc.

General

The SCL load cell is a compression load cell using single column technology, and is particularly suitable for weighing applications on weighbridges.

The SCL load cell is made of stainless steel and is compact, and is sealed under prolonged immersion (IP 68).

Options

- Ex version for use in explosive zone. (EEx ia II C T6).

Conformity

- Test certificate No. TC5404 according to OIML R60.

Available models

- SCL 35t : 1000 d (C1)
- SCL 35t : 3500 d (C3.5) et 2 x 3500 d (C3.5MB)
- SCL 35t : 5000 d (C5) et 2 x 5000 d (C5MB)
- SCL 35t : 7000 d (C7) et 2 x 7000 d (C7MB)
- SCL 35t Ex : 1000 d - C1
- SCL 35t Ex : 3500 d - C3.5
- SCL 35t Ex : 5000 d - C5
- SCL 35t Ex : 7000 d - C7
- SCL 55t : 1000 d (C1)
- SCL 55t : 3500 d (C3.5) et 2 x 3500 d (C3.5MB)
- SCL 55t : 5000 d (C5) et 2 x 5000 d (C5MB)
- SCL 55t : 7000 d (C7) et 2 x 7000 d (C7MB)
- SCL 55t Ex : 1000 d - C1
- SCL 55t Ex : 3500 d - C3.5
- SCL 55t Ex : 5000 d - C5
- SCL 55t Ex : 7000 d - C7



Dimensions :

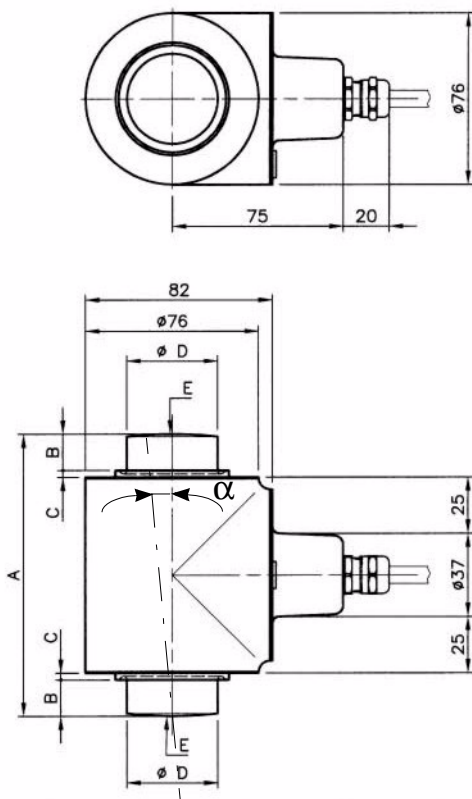

α : Angle d'inclinaison maximum autorisé : 5°.

LOAD CELL	A	F	C	Ø D	Radius E
SCL-35t	125	16	3	40	175
SCL-55t	153	23	10	48	225

Dimensions in mm and tolerances according to ISO 2768 m, medium accuracy.

Environmental characteristics

- Temperature range
 - Recommended - 10 °C / + 40 °C
 - Storage - 40 °C / + 90 °C
- Sealing and protection according to DIN 40-050.....IP 68

Mechanical characteristics

- Load limit 150% Emax
- Breaking load..... 300% Emax
- Maximum lateral load 10% Emax

Metrological characteristics

Accuracy class*		C3.5	C3.5MB	C1	C5MB	C7MB
Maximum range (E _{max})	t	35/55 t	35/55 t	35/55 t	35/55 t	35/55 t
Verification interval (v min)	kg	E _{max} /11666	E _{max} /23333	E _{max} /5000	E _{max} /23333	E _{max} /23333
Minimum usage range (E _{min})	% E _{max}	0	0	0	0	0

* The accuracy class option MB are conform with international recommendation OIML R60, for multi-range applications.

Electrical characteristics

- AC or DC power supply voltage 5 à 20V
- Input impedance..... 1 200 Ω ± 60 Ω
- Output impedance 1 000 Ω ± 10 Ω
- Insulation > 5000 MΩ
- Sensitivity (S) 2 mV/V ±1%
- Tolerance on the output ratio %S* ≤ ± 0,05 % S
- Zero unbalance ≤ ± 1 % S

Combined error*	%S	≤0,0180	≤0,0130	≤0,0180	≤0,0130	≤0,0130
Fidelity error	%S	≤0,0100	≤0,0100	≤0,0100	≤0,0100	≤0,0100
Temperature effect on sensitivity	%S/°C	≤0,0007	≤0,0007	≤0,0007	≤0,0007	≤0,0007
Effect of temperature on the signal at minimum dead load.	%S/°C	≤0,0012	≤0,0006	≤0,0012	≤0,0006	≤0,0006
Return of the output signal at minimum dead load.	%S	≤0,0140	≤0,0070	≤0,0140	≤0,0070	≤0,0070
Creep (30 minutes)	%S	≤0,0140	≤0,0140	≤0,0140	≤0,0140	≤0,0140

* The effect of temperature on the sensitivity and the "combined error" are balanced so that the sum is less than 70% of the error limit for non-automatic weighing instruments in accordance with the OIML R76 international recommendation . The combined error is defined as being the algebraic sum "non-linearity" and "hysteresis".

- Shielded cable with black PVC jacket :
 - Outside Ø 8 mm
 - Length 20 m
 - Maximum radius of curvature. 40 mm

* The "output ratio" is defined as being the quotient of the "output signal" by the "output impedance".

Your weighing specialist

Illustrations are not contractual. Precia-Molen reserves the right to modify at any time, without prior notice, the information contained in this leaflet.
PRECIA-MOLEN
 Teteringssedijk 53, 4817 MA Breda
 P.O.B. 3246, 4800 DE Breda
 The Netherlands
 Phone: +31 76 524 25 20
 Fax: +31 76 522 80 39
 Email: sales@preciamolen.nl
 Website: www.preciamolen.nl

